

# EXHIBIT Construction Guidelines

## Perimeter Wall Exhibit

Definition: Standard booth located on the outer perimeter wall of the exhibit floor.

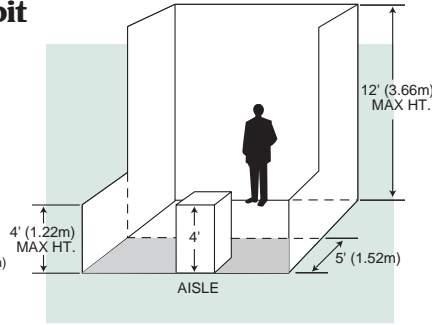
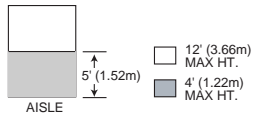

## Canopies and Ceilings

Definition: An exhibit component supported over an exhibitor's space for decorative purposes only.

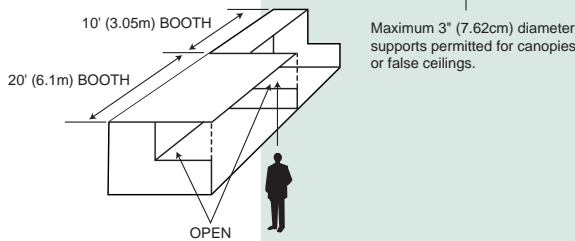
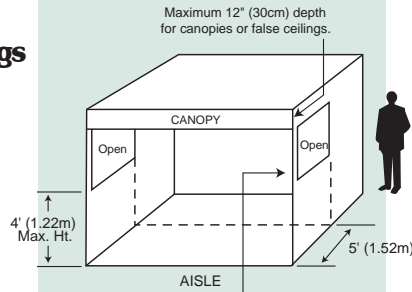

## Hanging Signs

Definition: An exhibit component suspended above an exhibit of four or more standard units back-to-back with an aisle on at least three sides, for the purpose of displaying graphics or identification.

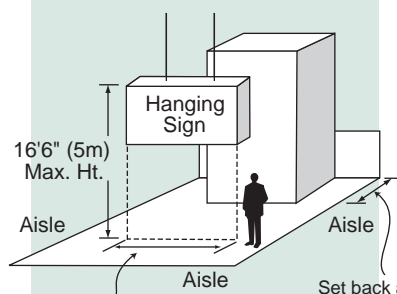

Length of sign not to exceed 50% of the corresponding dimension of the booth.  
 Set back at least 25% of the booth's width dimension from the back line of the booth.

## Standard Exhibit

Definition: One or more standard units in a straight line (minimum booth size is 10' x 10' = 100 sq.ft.)

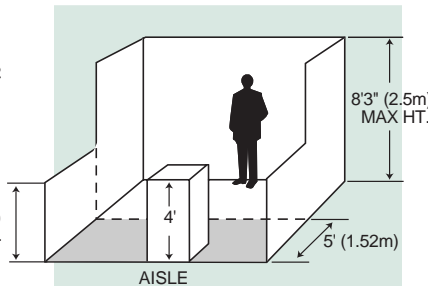

Display fixtures over 4' (1.22 m) high must be confined to that area of the booth that is at least 5' (1.52 m) from the aisle line.

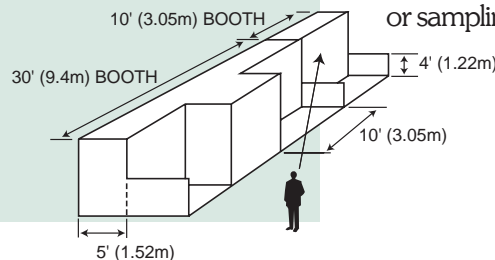

## Island Booth

Definition: Exhibit with aisles on four sides.

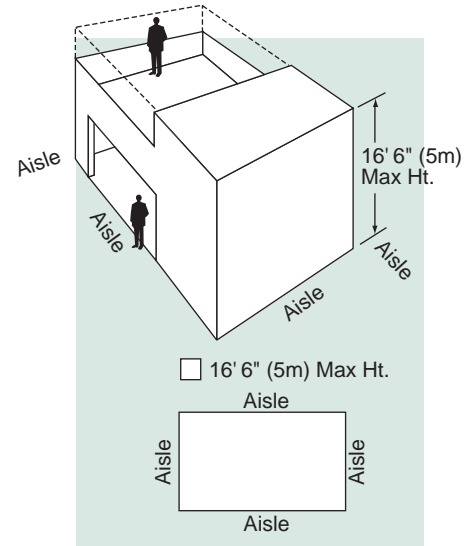

## Peninsula Exhibit

Definition: Exhibit with one or more display levels in four or more standard units back-to-back with an aisle on three sides.

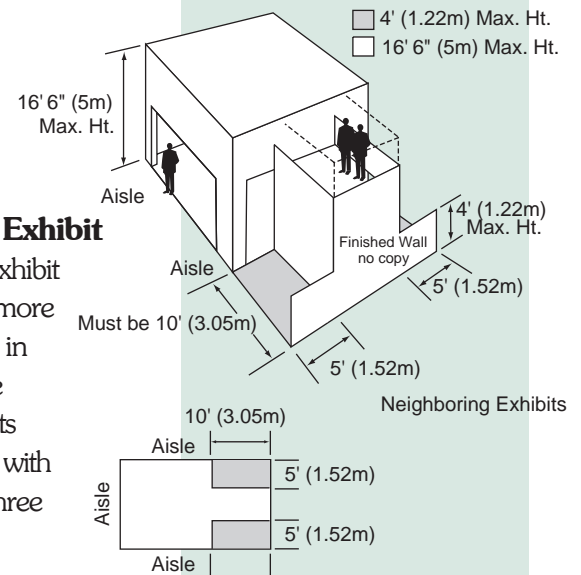

## Demonstrating/Sampling

The part of the exhibit program involving the interaction of exhibit personnel and their audience through corporate presentations, product demonstrations or sampling.

